



Tiltable Indicator

DB-1H SERIES

Bench Scale

The CAS DB-1H Bench Scale has a pivot-type indicator that tilts up & down for easy viewing. Like most bench scales the DB-1H is designed for rough industrial conditions. High quality and efficient in warehouses, incoming goods or shipping departments. The CAS DB-1H Bench Scale is built to stand up to tough treatment like jolt, vibration and overload.

- Easy to Operate
- Rigid Design for Versatile Use
- Pivot Type Indicator
- Dual Interval



CAS

DB-1H SERIES | Bench Scale

SPECIFICATIONS

Model	DB-1H Series	
Max. Capacity (kg)	60	150
Readability (g)	10/20	20/50
External Resolution	1/3,000 (Dual Interval)	
Display Digit	5 Digits (Weight)	
Display Type	VFD (20mm)	
Operating Temp.	-10°C~40°C	
Power	AC 110/220V, 50/60Hz	
Platter Size (mm)	400(W) x 510(D)	
Dimensions (mm)	420(W) x 635(D) x 765(H)	
Product Weight (kg)	19	

FEATURES

- Solid Built Frame
- Soft Touch Tact Switch
- Easy-to-read VFD Display
- Die-casting Platform & Stainless Steel Weighing Pan
- Auto Span Adjustment
- Auto Zero Tracking

OPTIONS

- RS-232C interface

KEYBOARD & DISPLAY



DIMENSIONS

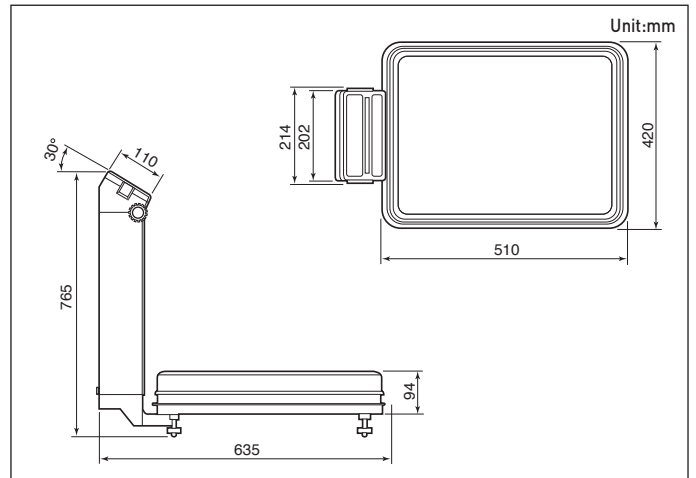

CAS

CAS BLDG., # 440-1, SUNGNAE-DONG,
GANGDONG-GU, SEOUL, KOREA

TEL_+ 82 2 2225 3500

FAX_+ 82 2 475 4668

<http://www.globalcas.com>

Specifications are subject to change for improvement without prior notice.