



1.2" LED display



Wireless Remote Control

CASTON-II SERIES

Crane Scale

CASTON-II is a rugged heavy-duty hanging scale for various industrial environments. The series is applicable in industrial areas including manufacturing factories and also heavy-duty industrial plants. Equipped with a wireless remote control function which makes operation more efficient and safe.



CASTON-II SERIES | Crane Scale

SPECIFICATIONS

Model	0.5THB	1THB	2THB	3THB	5THB
Max. Capacity (kg)	500	1,000	2,000	3,000	5,000
Readability (kg)	0.2	0.5	1	1	2
External Resolution	1/2,500	1/2,000	1/2,000	1/3,000	1/2,500
Display Digit	5 Digits				
Display Type	LED (1.2 inch)				
Operating Temp.	-10°C~40°C				
Power	DC 12V				
Dimensions (mm)	230(W) x 370(D) x 380(H)	230(W) x 370(D) x 474(H)	230(W) x 370(D) x 518(H)		
Product Weight (kg)	15	17	20		

FEATURES

- Standard wireless remote controller
- 2x Rechargeable battery packs & charger included
- Battery operated with low battery indication
- on/off, zero, tare, and hold function
- Easy-to-read 1.2" LED display
- Auto span adjustment & zero tracking

DISPLAY & KEY PAD

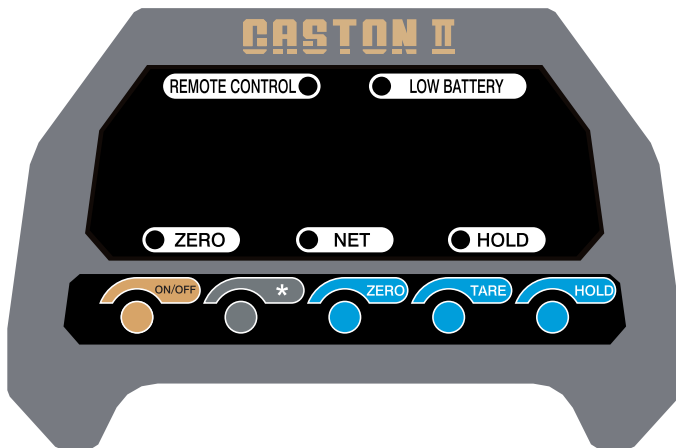

DIMENSIONS

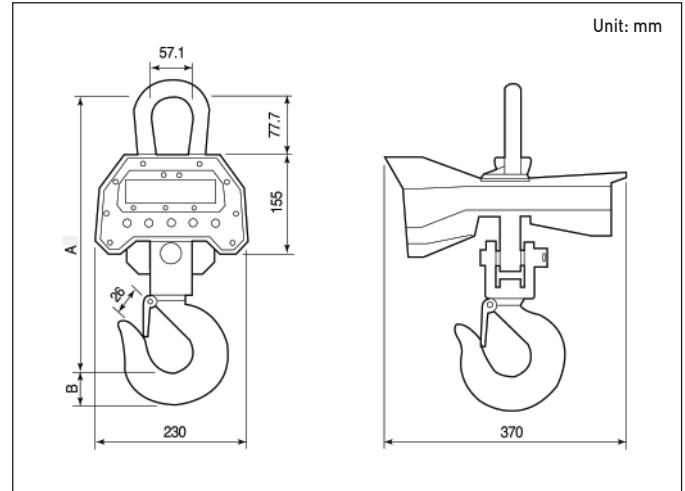

Model	A	B
0.5 THB	350	30
1 THB	350	30
2 THB	430	44.5
3 THB	430	44.5
5 THB	474	44.5



CAS BLDG., # 440-1, SUNGNAE-DONG,
GANGDONG-GU, SEOUL, KOREA

TEL_ 82 2 2225 3500

FAX_ 82 2 475 4668

<http://www.globalcas.com>

Specifications are subject to change for improvement without prior notice.